

# รถยกสูงทั้งไฟฟ้า

## SEMI ELECTRIC STACKER

### HKA SERIES

- รับน้ำหนัก 1000-2000 กก.
- ยกสูง 1600-3500 มม.
- ปรับความกว้างงาได้
- ยกขึ้น-ลงด้วยระบบไฟฟ้า
- ใช้แรงคนลากเพื่อเคลื่อนที่
- ปลอดภัยด้วยตัวล็อกเบรกล้อและปุ่มหยุดฉุกเฉิน
- เหมาะสำหรับยกชิ้นงานขึ้นที่สูง ยกซ้อนพาเลทสินค้า ชั้นบนชั้นสต็อกสินค้าในโกดัง

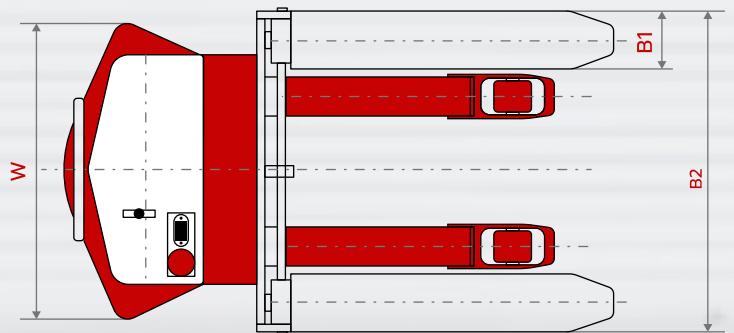
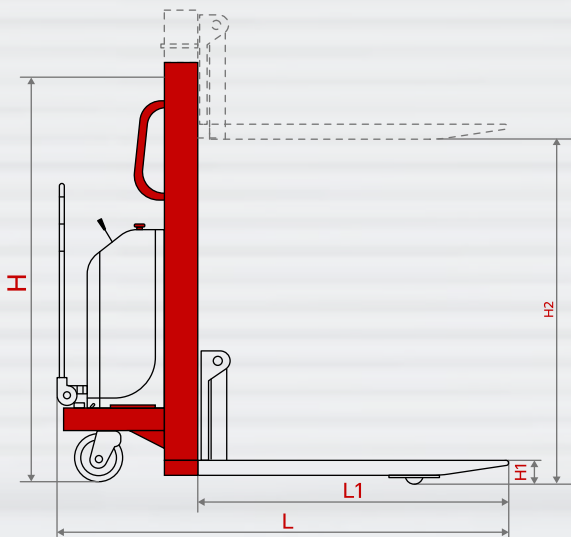

HAND CONTROL & UP-DOWN CONTROL



SAFETY FOOT BRAKE BATTERY CHARGER

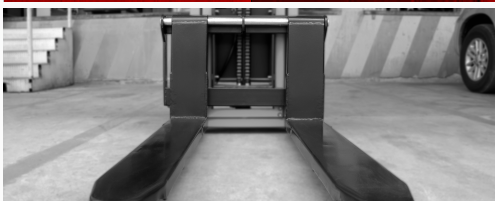

ADJUSTABLE FORK

MODEL	HKA1016	HKA1020	HKA1025	HKA1030	HKA1035
Capacity (kg)			1000		
Max. Fork Height (H2) (mm)	1600	2000	2500	3000	3500
Min. Fork Height (H1) (mm)			88		
Individual Fork Width (B1) (mm)			160		
Fork Length (L1) (mm)			1150		
Fork Overall Width (B2) (mm)	540		680		
Load Roller (mm)			Ø 80x70		
Steering Roller (mm)			Ø 180x50		
Overall Length (L) (mm)	1745		1788		
Overall Width (W) (mm)			800		
Overall Height (H) (mm)	2078	1640	1890	2140	2390
Battery (V/Ah/h)	12/60/5		12/100/5		
Power Pack (V/kw/L)			12/1.5		
Charger (V/A)	12/6		12/10		
Net Weight (kg)	220	310	330	350	360

Note: Specification is subject to change without notice.

# รถยกสูงทั้งไฟฟ้า

## SEMI ELECTRIC STACKER

### HKA SERIES

MODEL		HKA1516	HKA1520	HKA1525	HKA1530	HKA1535
Capacity	(kg)	1500				
Max. Fork Height (H2)	(mm)	1600	2000	2500	3000	3500
Min. Fork Height (H1)	(mm)	90				
Individual Fork Width (B1)	(mm)	160				
Fork Length (L1)	(mm)	1150				
Fork Overall Width (B2)	(mm)	540	680			
Load Roller	(mm)	Ø 80x70				
Steering Roller	(mm)	Ø 180x50				
Overall Length (L)	(mm)	1720	1800			
Overall Width (W)	(mm)	800				
Overall Height (H)	(mm)	2078	1640	1890	2140	2390
Battery	(V/Ah/h)	12/100/5				
Power Pack	(V/kw/L)	12/1.5				
Charger	(V/A)	12/10				
Net Weight	(kg)	270	315	335	355	365

Note: Specification is subject to change without notice.

# รถยกสูงทั้งไฟฟ้า

## SEMI ELECTRIC STACKER

### HKA SERIES

MODEL		HKA2016	HKA2020
Capacity	(kg)	2000	
Max. Fork Height (H2)	(mm)	1600	2000
Min. Fork Height (H1)	(mm)	90	
Individual Fork Width (B1)	(mm)	160	
Fork Length (L1)	(mm)	/ 1150	
Fork Overall Width (B2)	(mm)	540	680
Load Roller	(mm)	O 80x70	
Steering Roller	(mm)	O 180x50	
Overall Length (L)	(mm)	1745	1800
Overall Width (W)	(mm)	800	
Overall Height (H)	(mm)	2078	1640
Battery	(V/Ah/h)	12/120/5	
Power Pack	(V/kw/L)	12/1.5	
Charger	(V/A)	12/12	
Net Weight	(kg)	320	365

Note: Specification is subject to change without notice.