

สแตกเกอร์กึ่งไฟฟ้า

SEMI ELECTRIC STACKER

(MODIFIED)

- ยกสูงไฟฟ้า เคลื่อนที่ด้วยแรงคน
- รับน้ำหนัก 1,000-2,000 kg
- ยกสูงสุด 2,000-3,500 mm
- ใช้สำหรับยกชิ้นงานบนพาเลทเลขขึ้นที่สูง ชั้นแร็ค ชั้นสต็อกสินค้า ในโกดัง

สิ่งที่ปรับเปลี่ยน

- ทำแผงกันชนขนาด 300x730 mm ป้องกันวัตถุหล่น
- ติดฟลอร์ล็อกประคองรถ 1 ชุด ช่วยป้องกันรถลื่นไถล
- ใส่नीอตเสริมงานด้านหลัง และनीอตล็อกกล่องฟากรอบ
- เปลี่ยนเป็นล้อไนลอนทั้งคัน เพื่อให้สามารถใช้กับพื้นปูนได้

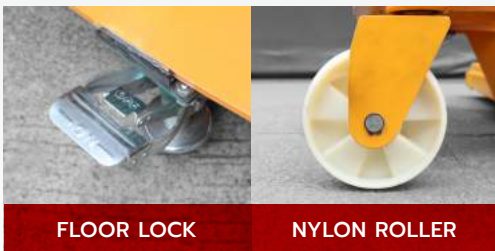
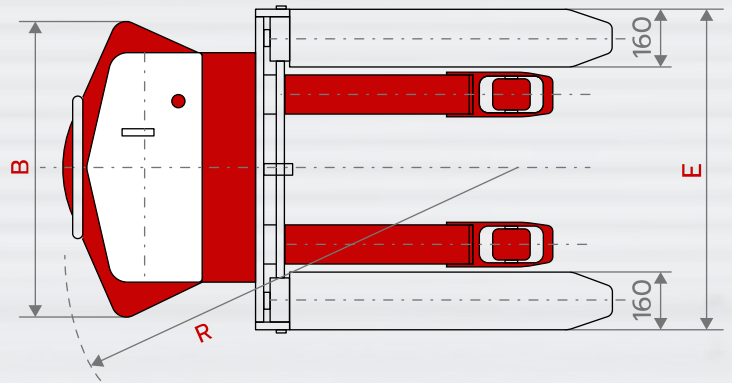
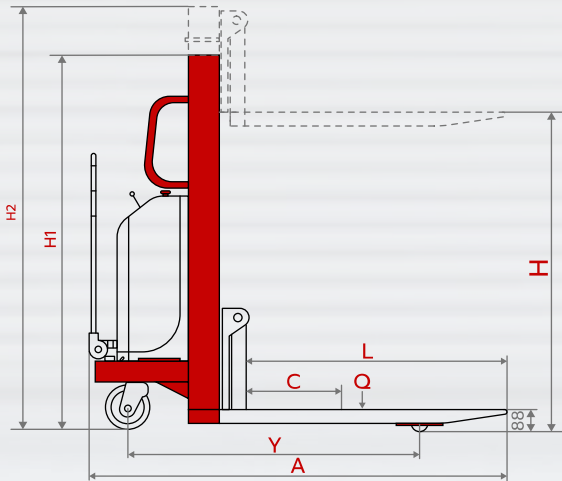

MODEL		EMS1016	EMS1020	EMS1025	EMS1030
Capacity (Q)	(kg)	1000			
Load Center (C)	(mm)	600			
Wheels Base (Y)	(mm)	1305		1345	
Max. Fork Height (H)	(mm)	1600	2000	2500	3000
Min. Fork Height	(mm)	88			
Overall Length (A)	(mm)	1700		1740	
Overall Width (B)	(mm)	700			
Overall Height (H1)	(mm)	2078	1640	1890	2140
Individual Fork Width	(mm)	160			
Fork Overall Width (E)	(mm)	346-710			
Turn Radius (R)	(mm)	1425			1450
Load Roller	(mm)	Ø 80x70			
Steering Roller	(mm)	Ø 180x50			
Lifting	(mm/s)	82/125			
Lowering	(mm/s)	90/74			
Motor Lifting	(V/KW)	12/15			
Battery	(V/Ah)	12/100			
Charger	(V/A)	12/6		12/10	
Net Weight	(kg)	220	310	330	350

Note: Specification is subject to change without notice.

สแตกเกอร์ทั้งไฟฟ้า

SEMI ELECTRIC STACKER

(MODIFIED)

MODEL		EMS1516	EMS1520	EMS1525	EMS1530
Capacity (Q)	(kg)	1500			
Load Center (C)	(mm)	600			
Wheels Base (Y)	(mm)	1345	1325		
Max. Fork Height (H)	(mm)	1600	2000	2500	3000
Min. Fork Height	(mm)	88			
Overall Length (A)	(mm)	1800			
Overall Width (B)	(mm)	700			
Overall Height (H1)	(mm)	2074	1640	1890	3000
Individual Fork Width	(mm)	160			
Fork Overall Width (E)	(mm)	346-710			
Turn Radius (R)	(mm)	1425			
Load Roller	(mm)	Ø 80x70			
Steering Roller	(mm)	Ø 180x50			
Lifting	(mm/s)	57/87			
Lowering	(mm/s)	62/52			
Motor Lifting	(V/KW)	12/1.5			
Battery	(V/Ah)	12/100			
Charger	(V/A)	12/10			
Net Weight	(kg)	270	315	335	400

Note: Specification is subject to change without notice.

สแตกเกอร์ทั้งไฟฟ้า

SEMI ELECTRIC STACKER

(MODIFIED)

MODEL		EMS2016	EMS2020
Capacity (Q)	(kg)	2000	
Load Center (C)	(mm)	600	
Wheels Base (Y)	(mm)	1325	
Max. Fork Height (H)	(mm)	1600	2000
Min. Fork Height	(mm)	88	
Overall Length (A)	(mm)	1800	
Overall Width (B)	(mm)	700	
Overall Height (H1)	(mm)	2074	1640
Individual Fork Width	(mm)	160	
Fork Overall Width (E)	(mm)	346-710	
Turn Radius (R)	(mm)	1425	
Load Roller	(mm)	Ø 80x70	
Steering Roller	(mm)	Ø 180x50	
Lifting	(mm/s)	45/75	
Lowering	(mm/s)	62/52	
Motor Lifting	(V/Kw)	12/1.5	
Battery	(V/Ah)	12/100	12/120
Charger	(V/A)	12/12	
Net Weight	(kg)	320	365

Note: Specification is subject to change without notice.